

USER'S GUIDE

SANDG INNOVA 2020



TEXTILE AIR ENGINEERING DIVISION

'Bharat House, 5th Floor,
104 Bombay Samachar Marg,
Fort, Mumbai – 400 001.
T : +91.22.6637 8200
F : +91.22.2267 5601
E : info@batliboi.com

PREFACE

Thank you for purchasing of our unique SANDG INNOVA 2020. We are very confident that your new purchase will greatly beneficial for you in terms of **P r o d u c t i o n M o n i t o r i n g & C o n t r o l l i n g .**

This Manual shows how to get the most of your new purchase from turning on the power switch to basic Trouble Shooting. Take some time to read it carefully before operating your SANDG INNOVA 2020. However, after reading this Manual if you are not sure about how to do something, please feel free to contact us. We will be glad to support you.

CONTENTS

1.SUPERNOVA-2020 PLC — 1 No.

FRONT VIEW

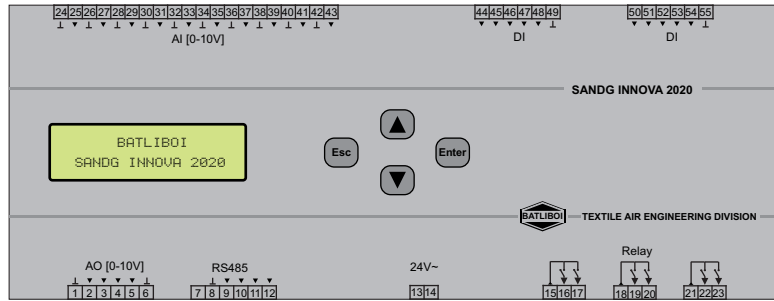

KEY FUNCTIONS

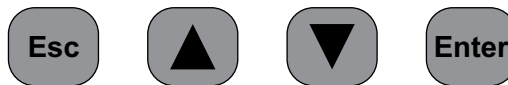

The 4 keys are used to edit a number in setting menu and password editing



Enter key – it have 3 functions

1. Enter to settings menu
2. Shift rite digit (rite curser move)
3. Save setting number when rite lest digit



Increment key – this key increment number when it press (01234567890123...)



Decrement key- this key decrement number when it press (98764321098765...)



Esc key – it have 3 functions

1. Exit to settings value when left lest digit
2. Shift left digit (Left curser move)
3. Exit from setting menu

TECHNICAL SPECIFICATIONS

- | | | |
|-----------------------|---|--------------|
| 1. Supply voltage | — | 24V AC or DC |
| 2. Output Load(relay) | — | 5A/230VAC |

PROGRAM FLOW

When the unit is powered on the Display Shows as



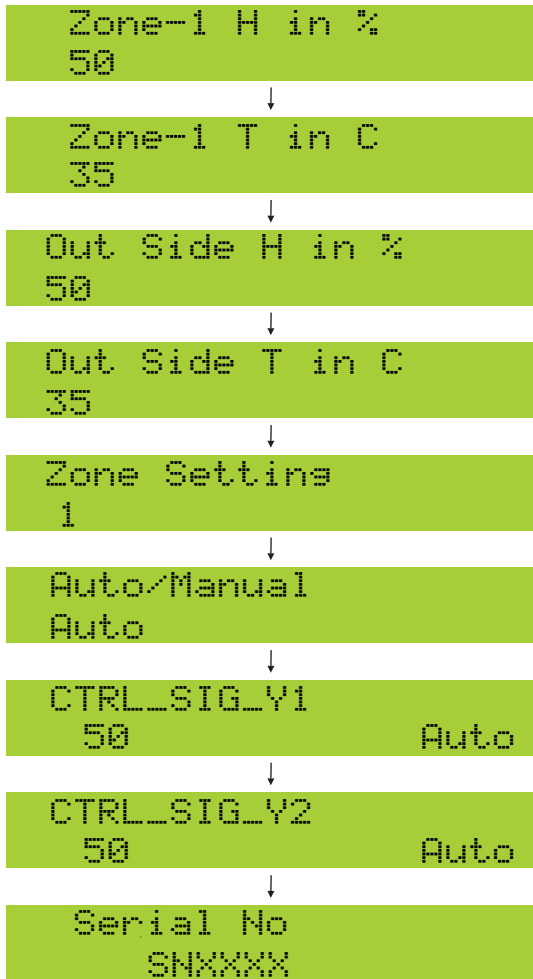

Normal display mode [1-Zone]

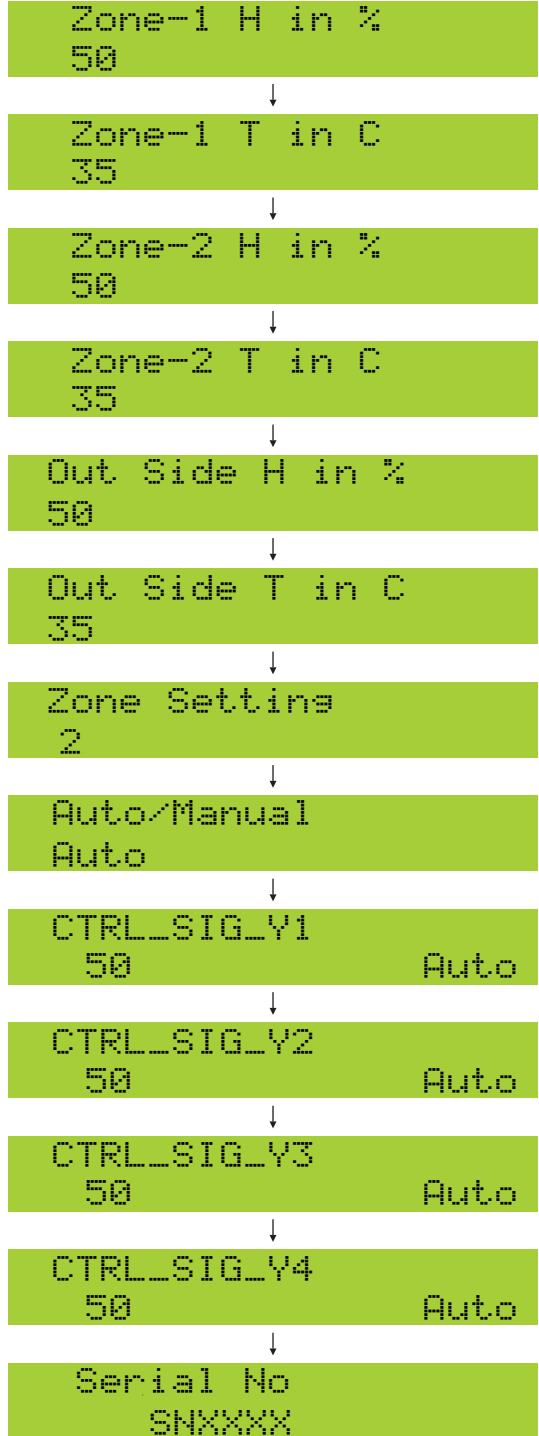

Normal display mode [2-Zone]



Press  and  Button
for next screen

Main Menu Detail

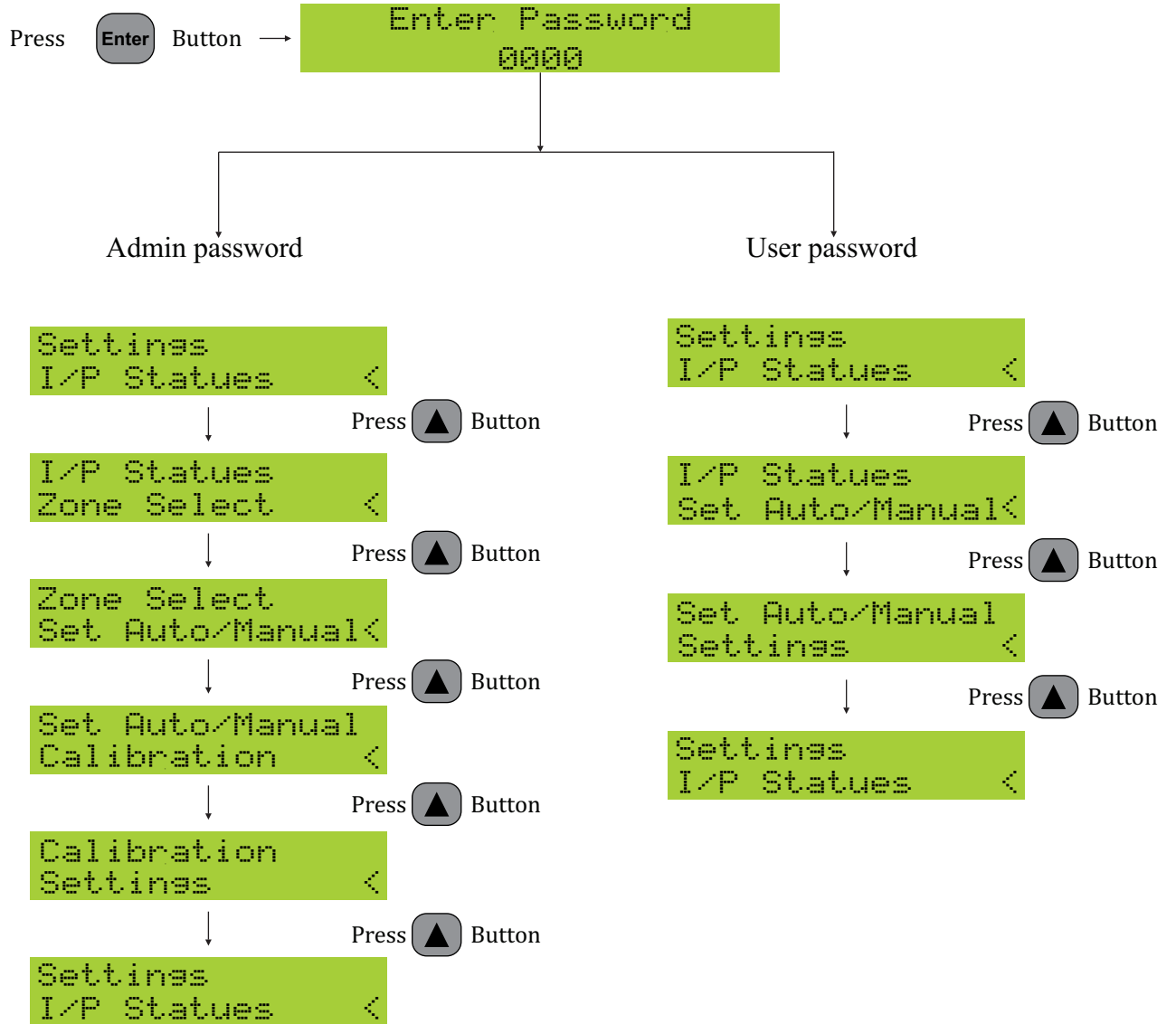

Settings Menu Detail [Zone - 1]

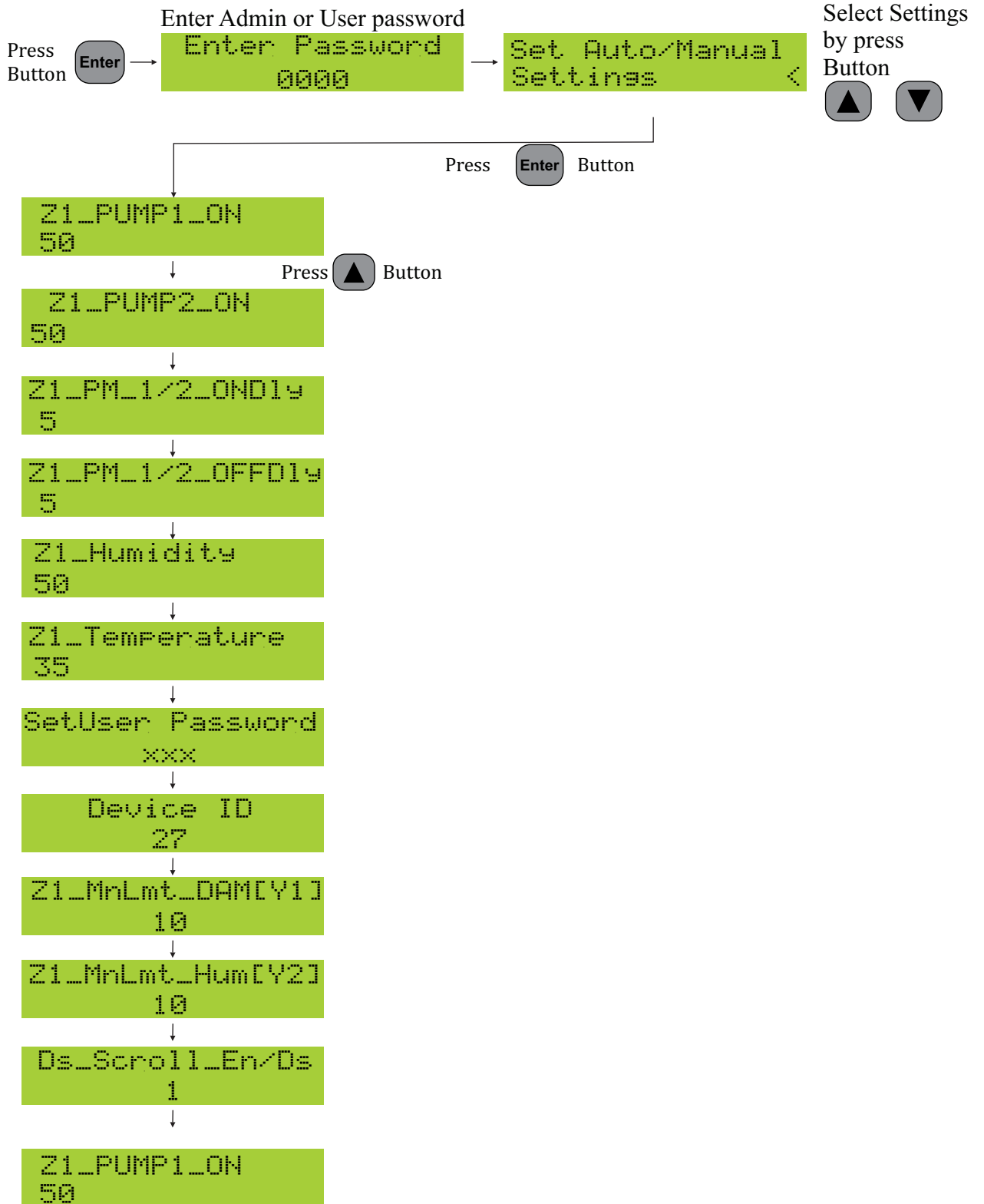

Settings Menu Detail [Zone - 2]

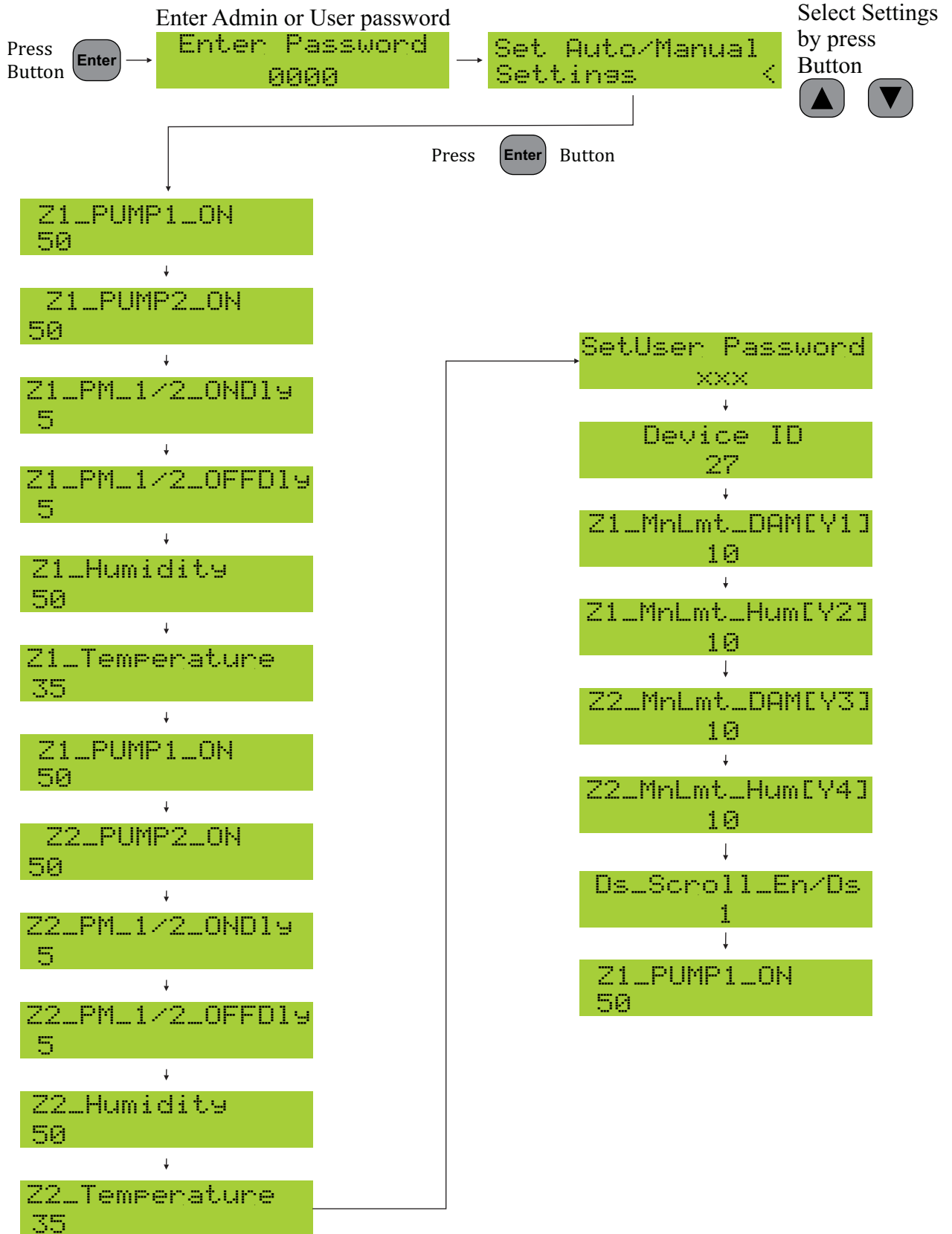

Input Statuses Menu Detail

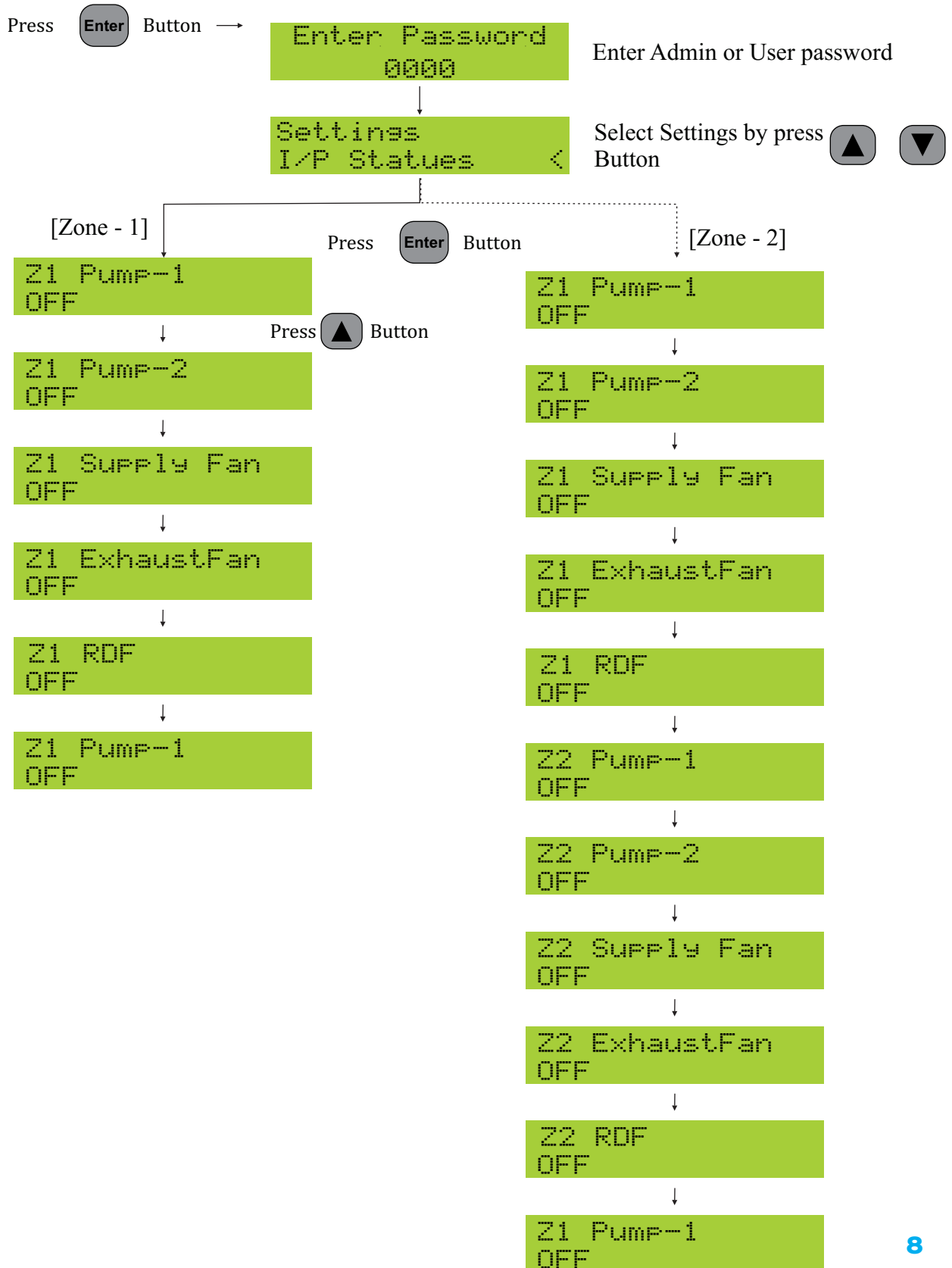

Auto / Manual Setting Menu Detail

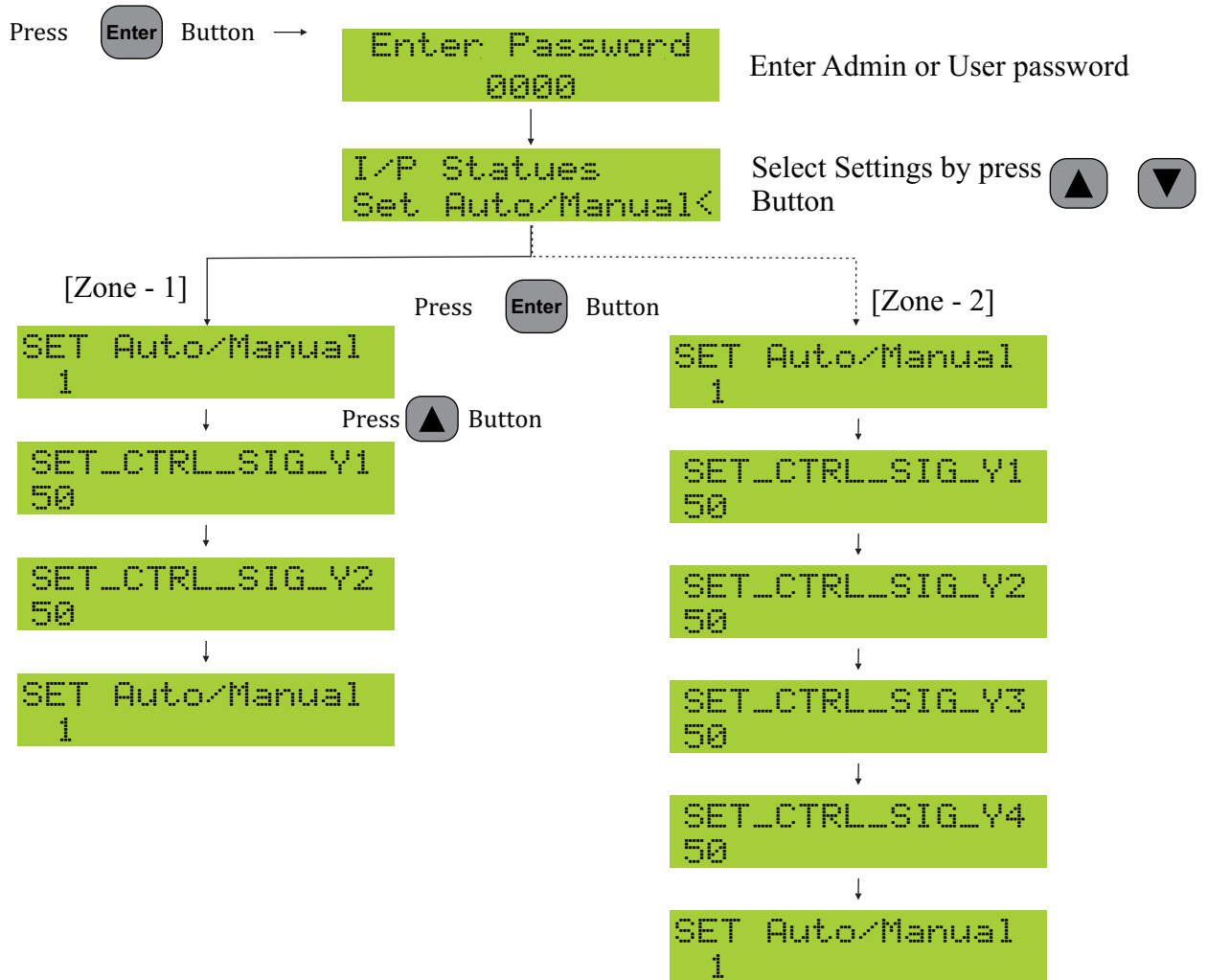

Zone Setting Menu Detail

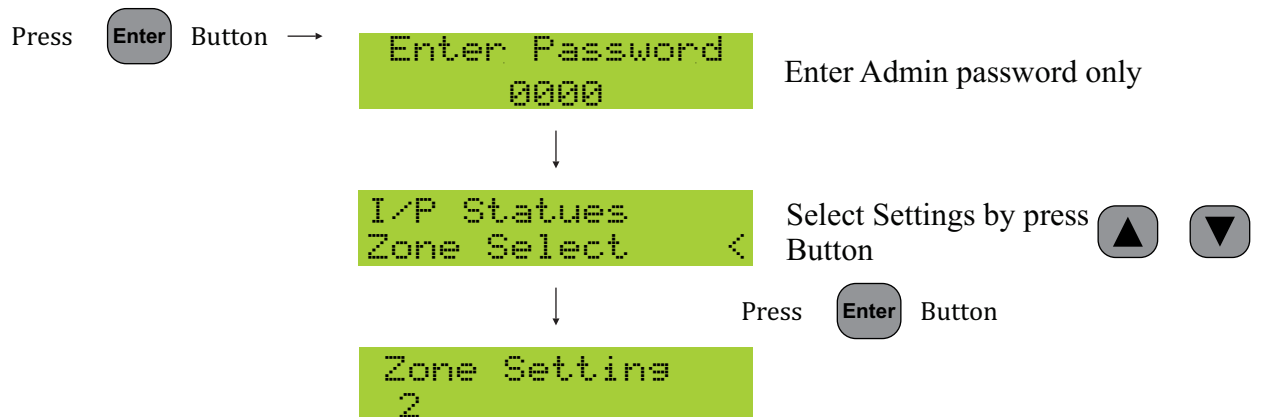

Calibrations Setting Menu Detail

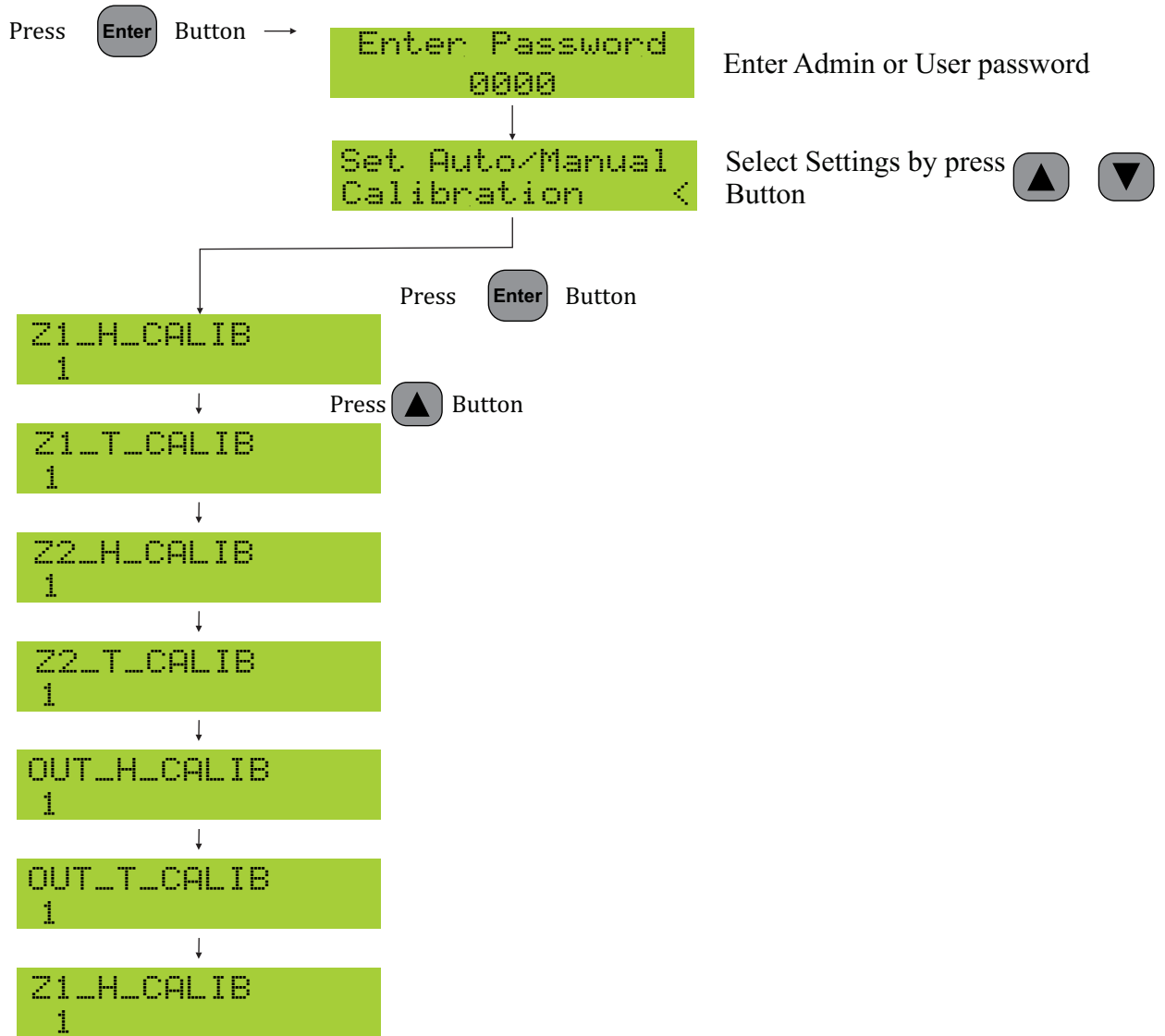

Title		SANDG INNOVA 2020	
Size	A	Document Number	1
Date:	Friday, June 16, 2017	Sheet	1 of 1

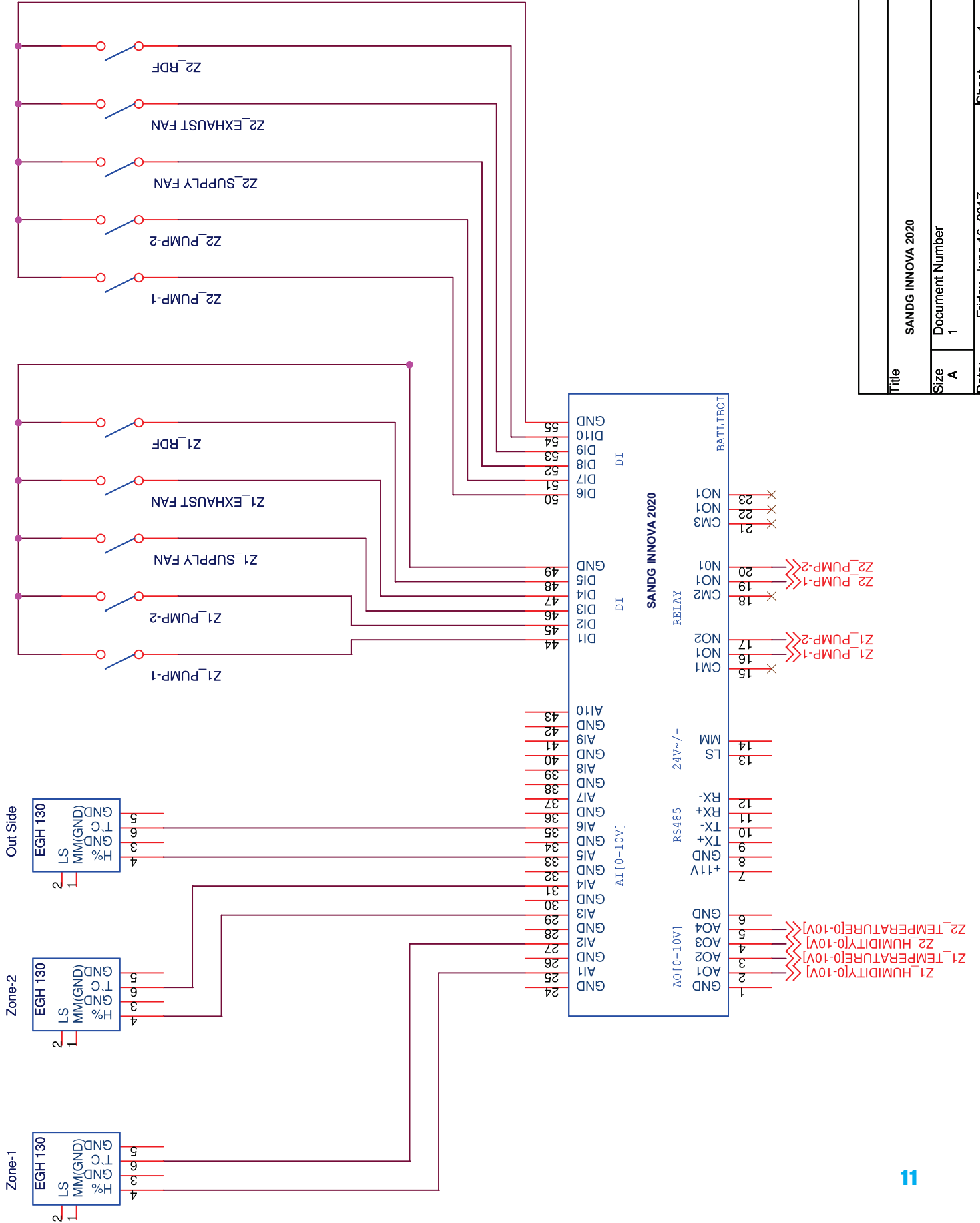

WARRANTY

SANDG INNOVA 2020

The above equipment has been supplied after testing it thoroughly and is free from any kind of manufacturing defects. The Warranty is effective from _____ to _____

against any manufacturing defects, when used in accordance with instruction manual.

However, the Warranty is void if the equipment is misused or lost or damaged in transit or an attempt made to repair unauthorized.

Our liability under this warranty is limited to the repair or replacement at our discretion when the equipment is sent to our factory.

No other warranty expressed or implied is applicable.

for BATLIBOI

Authorised Signatory.

Customer Address:

SERIAL NUMBER:

NOTE: Please mention Serial No. in all Your Correspondence.